

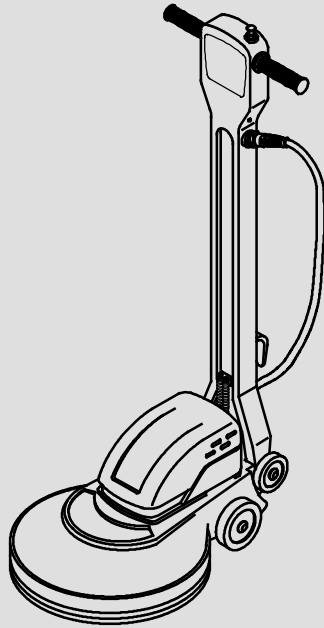

BR- 1200- NDC BR- 1600- NDC

High Speed Floor Burnisher

Parts Manual



Model Part No.:
9007328 - BR- 1200- NDC (120V, CANADIAN MODEL, CSA)
9007347 - BR- 1600- NDC (120V, US / INTL MODEL -
(Model Can Not Be Sold In Canada)
9007348 - BR- 1600- NDC (230V)



For the latest Parts Manuals and other
language Operator manuals, visit:

www.tennantco.com/manuals

9007346
Rev. 02 (08-2018)



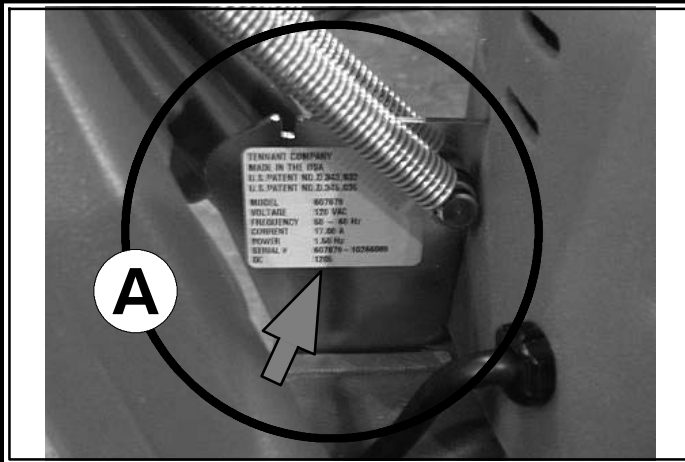

Ref	Part No.	Serial Number	Description	Qty.
1	82681	(000000-)	Bracket Wldt, Lpg Mount	1
∇ 2	63810	(000000-)	Latch Assy, Lpg Tank Mtg, W/Nut	4
▲ 3	51839	(000000-)	Nut Adjustable, Lpg Tank Mtg	2
4	49263	(000000-)	Tie, Cable	3
(C) 5	82556	(000000- 001039)	Bracket, Vaporizer	1
	54930	(000000-)	Vaporizer	1

HOW TO ORDER PARTS - See diagram above

Only use TENNANT Company supplied or equivalent parts. Parts and supplies may be ordered online, by phone, by fax or by mail.

Follow the steps below to ensure prompt delivery.

1. (A) Identify the machine model.
2. (A) Identify the machine serial number from the data label.
3. (B) Ensure the proper serial number is used from the parts list.
4. Identify the part number and quantity.
Do not order by page or reference numbers.
5. Provide your name, company name, customer ID number, billing and shipping address, phone number and purchase order number.
6. Provide detail shipping instructions.

- (C) ∇ - identifies an assembly
 ▲ - identifies parts included in assembly

Please fill out at time of installation for future reference.

Model No. - _____

Serial No. - _____

Machine Options - _____

Sales Rep. - _____

Sales Rep. phone no. - _____

Customer ID Number - _____

Installation Date - _____

Tennant Company

PO Box 1452
 Minneapolis, MN 55440
 Phone: (800) 553- 8033

www.tennantco.com
 www.nobles.com

Specifications and parts are subject to change without notice.

Copyright © 2010, 2014, 2018 TENNANT Company, Printed in U.S.A.

CN	<p>如何订购部件 - 参见下表</p> <p>仅使用 TENNANT 公司提供的或同等部件。部件和供应可以在线订购，通过电话、传真或邮件订购。请遵循下面的步骤确保及时交付。</p> <ol style="list-style-type: none"> 1. (A) 确定机器型号。 2. (B) 从数据标签确定机器序列号。 3. (C) 确保使用部件列表中的正确序列号。 4. 确定部件号和数量。 不要按页面或参考编号订购。 5. 提供您的姓名、公司名称、客户 ID 号、付帐和送货地址、电话号码和采购单编号。 6. 提供详细的送货说明。 <hr/> <p>(D) ▽ - 确定组件 ▲ - 确定组件中包含的组件</p>	<p>请在安装时填写供未来参考。</p> <p>型号 - _____</p> <p>序列号 - _____</p> <p>机器选项 - _____</p> <p>销售代表 - _____</p> <p>销售代表电话号码 - _____</p> <p>客户 ID 编号 - _____</p> <p>安装日期 - _____</p>
-----------	--	--

ES	<p>CÓMO SOLICITAR PIEZAS - Consulte el diagrama anterior.</p> <p>Utilice sólo las piezas suministradas por TENNANT Company o piezas equivalentes. Puede solicitar las piezas a través de internet, por teléfono, por fax o por correo.</p> <p>Siga los siguientes pasos para que la entrega sea rápida.</p> <ol style="list-style-type: none"> 1. (A) Indique el modelo de máquina. 2. (B) Indique el número de serie de la etiqueta de datos. 3. (C) Asegúrese de que indica el número de serie correcto de la lista de piezas. 4. Indique la cantidad y el número de la pieza. No realice el pedido indicando el número de página o el de referencia. 5. Incluya su nombre, el nombre de la empresa, el ID de cliente, las direcciones de envío y facturación, el número de teléfono y el número del pedido de compra. 6. Facilite instrucciones de envío. <hr/> <p>(D) ▽ - identifica un conjunto ▲ - identifica piezas de un conjunto</p>	<p>Rellene estos datos cuando realice la instalación para utilizarlos como referencia en el futuro.</p> <p>Nº modelo - _____</p> <p>Nº serie - _____</p> <p>Opciones de la máquina - _____</p> <p>Vendedor - _____</p> <p>Nº teléfono vendedor - _____</p> <p>Nº cliente - _____</p> <p>Fecha de instalación - _____</p>
-----------	--	---

FR	<p>COMMENT COMMANDER DES PIÈCES DÉTACHÉES - Voir le schéma ci-dessus.</p> <p>Utilisez uniquement des pièces fournies par la société TENNANT ou équivalentes. Les pièces et fournitures peuvent être commandées en ligne, par téléphone, fax, ou par courrier.</p> <p>Suivez les étapes ci-dessous pour assurer une livraison rapide.</p> <ol style="list-style-type: none"> 1. (A) Identifiez le modèle de la machine. 2. (B) Identifiez le numéro de série de la machine, à partir de l'étiquette signalétique. 3. (C) Assurez-vous que le numéro de série correct est utilisé à partir de la liste de pièces détachées. 4. Identifiez le numéro de pièce et la quantité. Ne commandez pas par page ou numéros de référence. 5. Fournissez votre nom, le nom de votre société, votre numéro d'identification de client, l'adresse de facturation et d'expédition, le numéro de téléphone et le numéro du bon de commande. 6. Fournissez des instructions d'expédition détaillées. <hr/> <p>(D) ▽ - identifie un assemblage ▲ - identifie les pièces composant l'assemblage</p>	<p>A remplir au moment de l'installation à titre de référence.</p> <p>Nº du modèle - _____</p> <p>Nº de série - _____</p> <p>Options de la machine - _____</p> <p>Agent commercial - _____</p> <p>Nº tél. de l'agent commercial - _____</p> <p>Numéro d'identification client - _____</p> <p>Date d'installation - _____</p>
-----------	--	---

JP	<p>パーツの発注方法 ? 上記の図を参照してください</p> <p>TENNANT社製のパーツまたは同等品のみをお使いください。パーツやサプライ品のご注文は、オンライン、電話、FAX、または手紙でお願いいたします。確実にお届けできるように、以下の情報お知らせください。</p> <ol style="list-style-type: none"> 1. (A) 製品のモデル名をお知らせください。 2. (B) 製品のデータラベルに印刷されているシリアル番号をお知らせください。 3. (G) パーツリストを参照して、シリアル番号が正しいかご確認ください。 4. パーツ番号と数量をお知らせください。マニュアル/カタログのページ番号や参照番号でのご注文はご遠慮ください。 5. お客様のお名前、会社名、顧客ID番号、請求/発送先住所、電話番号、注文書番号をお知らせください。 6. 発送に関するご希望があれば、明記してください。 <hr/> <p>(D) ▽ - アセンブリを示します ▲ - アセンブリに含まれるパーツを示します</p>	<p>後日確認できるように、設置時に記入してください。</p> <p>モデルNo. - _____</p> <p>シリアルNo. - _____</p> <p>製品のオプション - _____</p> <p>販売代理店 - _____</p> <p>販売代理店の電話番号 - _____</p> <p>顧客ID番号 - _____</p> <p>設置日 - _____</p>
-----------	---	---

STANDARD PARTS

GENERAL RECOMMENDED MAINTENANCE
ITEMS 7
HANDLE GROUP 8
HANDLE GROUP - CONTD 10
BASE GROUP 12
ELECTRICAL DIAGRAM, 120V 14
ELECTRICAL DIAGRAM, 230V 14

GENERAL RECOMMENDED MAINTENANCE

GENERAL RECOMMENDED MAINTENANCE

GENERAL RECOMMENDED MAINTENANCE ITEMS

Part No.	Serial Number	Description	Qty.
1066506	(00000000-) Grip, Handle, Rnd	2
200821	(00000000-) Grip, Latch, Hdl, 1.62 X 1.25 X 1 Blk	1
130204	(00000000-) Cord, 14ga /3, 54.0l Blk [Sjt/Sjto]	1
130141	(00000000-) Strainrelief, Bshg [Sr7l- 2]	1
230855	(00000000-) Knob, Button, Lock Release, Alm	1
602849	(00000000-) Strainrelief, Cord, Ele, Pm08, Blk Nyl (120V)	1
130167	(00000000-) Strainrelief, Cord, Ele, Pm08, Blk Nyl (230V)	1
610974	(00000000-) Cord, Power, 14/3, 75ft Yel W/ Grip[Sto] (120V)	1
600396	(00000000-) Cord, Power, 1.5mm2/3 Blk [23meter Euro] (230V)	1
103066	(00000000-) Wheel, 04.0d 1.50w 0.50b, Gray	2
103067	(00000000-) Wheel, 05.0d 1.50w 0.50b, Gray	2
▽ 1033499	(00000000-) Driver, Pad, 20.0d, Flex	1
▲ 603538	(00000000-) Lock, Cntr, Gray	1
▲ 32505	(00000000-) Washer, Flat, 92b 156d 2.6l, Pad Driver	1
611695	(00000000-) Pulley, Pad Driver, Mold, 2 Brg	1
240075	(00000000-) Pulley, Drive, 3.25d, Belt, V[1200rpm Hs]	1
240076	(00000000-) Pulley, Drive, 4.00d, Belt, V[1600rpm Hs]	1
240078	(00000000-) Belt (1200rpm)	1
240079	(00000000-) Belt, Drive (1600rpm)	1

▽ ASSEMBLY

▲ INCLUDED IN ASSEMBLY

HANDLE GROUP

(S/N 00000000 - 10853052)

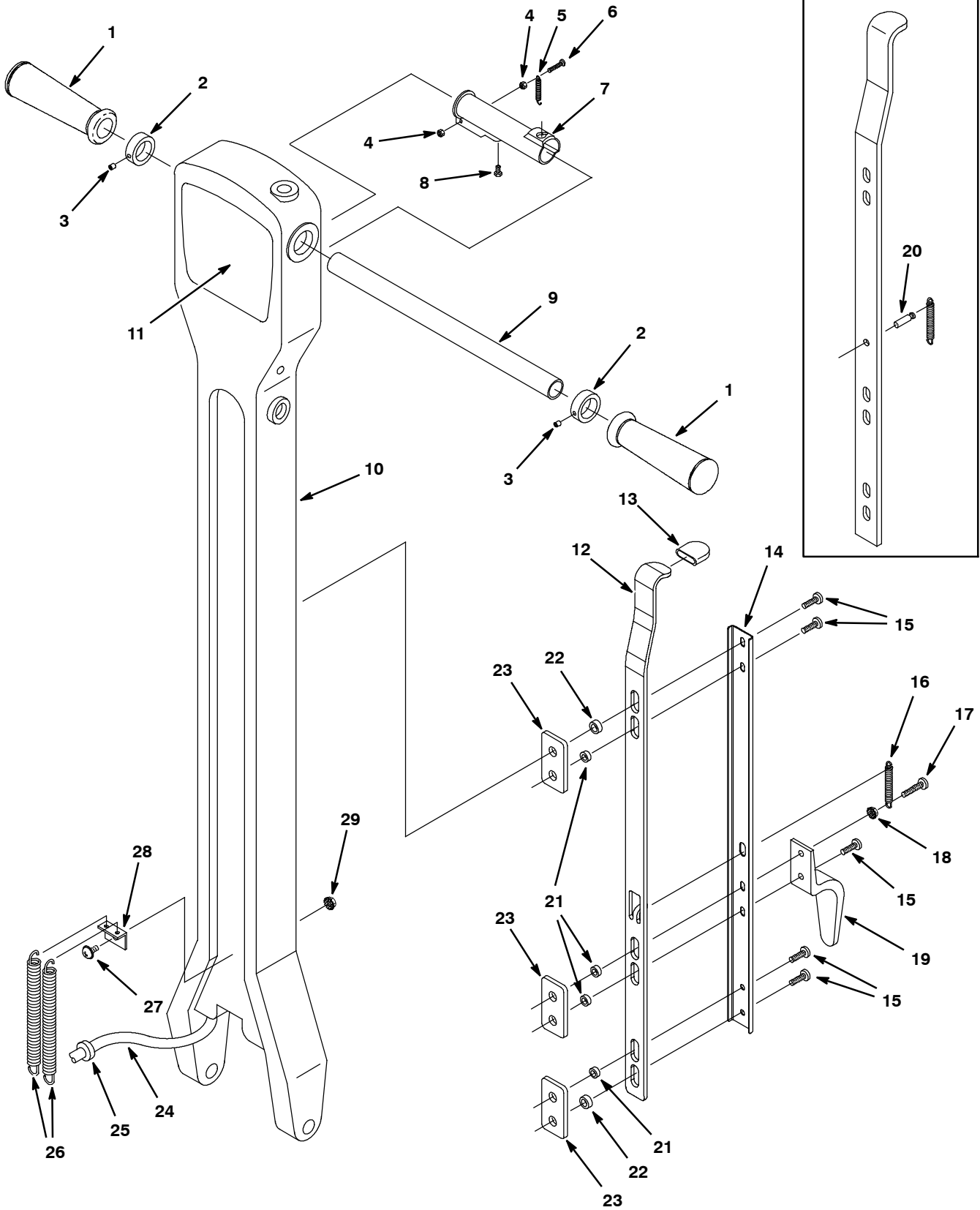

HANDLE GROUP

Ref.	Part No.	Serial Number	Description	Qty.
1	1066506	(00000000-) Grip, Handle, Rnd	2
2	605094	(00000000-) Collar, Handle	2
3	140859	(00000000-) Screw, Set, .25- 20 X 0.25, Soc	2
4	28990	(00000000-) Nut, Hex, Lock, #08- 32, NI, Ss	2
5	600987	(00000000-) Spring, Extn, 0.25od 0.03wir 01.3l, Mw	1
6	6010.16	(00000000-) Screw, Pan, 08- 32 X 1.00	1
7	100355	(00000000-) Sleeve, Locking, Grip, Handle	1
8	24672	(00000000-) Screw, Hex, .25- 20 X 0.75, Ss	1
9	230853	(00000000-) Tube, 0.76id 0.88od 15.0l, Stl	1
10	1033078	(00000000-) Handle, Rm- Cphg, Afmkt [B- 1600]	1
11	1060464	(00000000-) Label, Logo, Cmdty, Dual, Large	1
11	1060462	(00000000-) Label, Logo, Cmdty, Tco, Large	1
12	1075162	(10853053-) Handle, Latch	1
12	611141	(00000000- 10853052) Handle, Latch	1
13	200821	(00000000-) Grip, Latch, Hdl, 1.62 X 1.25 X 1 Blk	1
14	230859	(00000000-) Channel, .05, 1.4w 0.3 23.4l, H&S	1
15	140864	(00000000-) Screw, Trs, .25- 20 X 0.75, Phl, Ss, NI	5
16	140402	(00000000-) Spring, Extn, 0.375od 0.045wir 01.8l, Mw	1
17	140881	(00000000-) Screw, Trs, .25- 20 X 1.00, PI	1
18	140524	(00000000-) Nut, Hex, Lock, .25- 20, Kep	1
19	602750	(00000000-) Hook, Cord [Fr/ C Record]	1
20	140604	(00000000- 10853052) Pin, Grvd, 0.25d 0.75l, PI [Type G]	1
21	140147	(00000000-) Sleeve, P/M, 0.25b 0.44d 0.2l, PI	4
22	140146	(00000000-) Sleeve, P/M, 0.25b 0.50d 0.2l, PI	2
23	230852	(00000000-) Plate, Backing	3
24	130204	(00000000-) Cord, 14ga /3, 54.0l Blk [Sjt/Sjto]	1
25	130141	(00000000-) Strainrelief, Bshg [Sr7l- 2]	1
26	140437	(00000000-) Spring, Extn, 0.62od 0.07wir 06.0 [Lss]	2
27	140864	(00000000-) Screw, Trs, .25- 20 X 0.75, Phl, Ss, NI	1
28	230773	(00000000-) Bracket, Spring	1
29	140524	(00000000-) Nut, Hex, Lock, .25- 20, Kep	1

HANDLE GROUP - CONTD

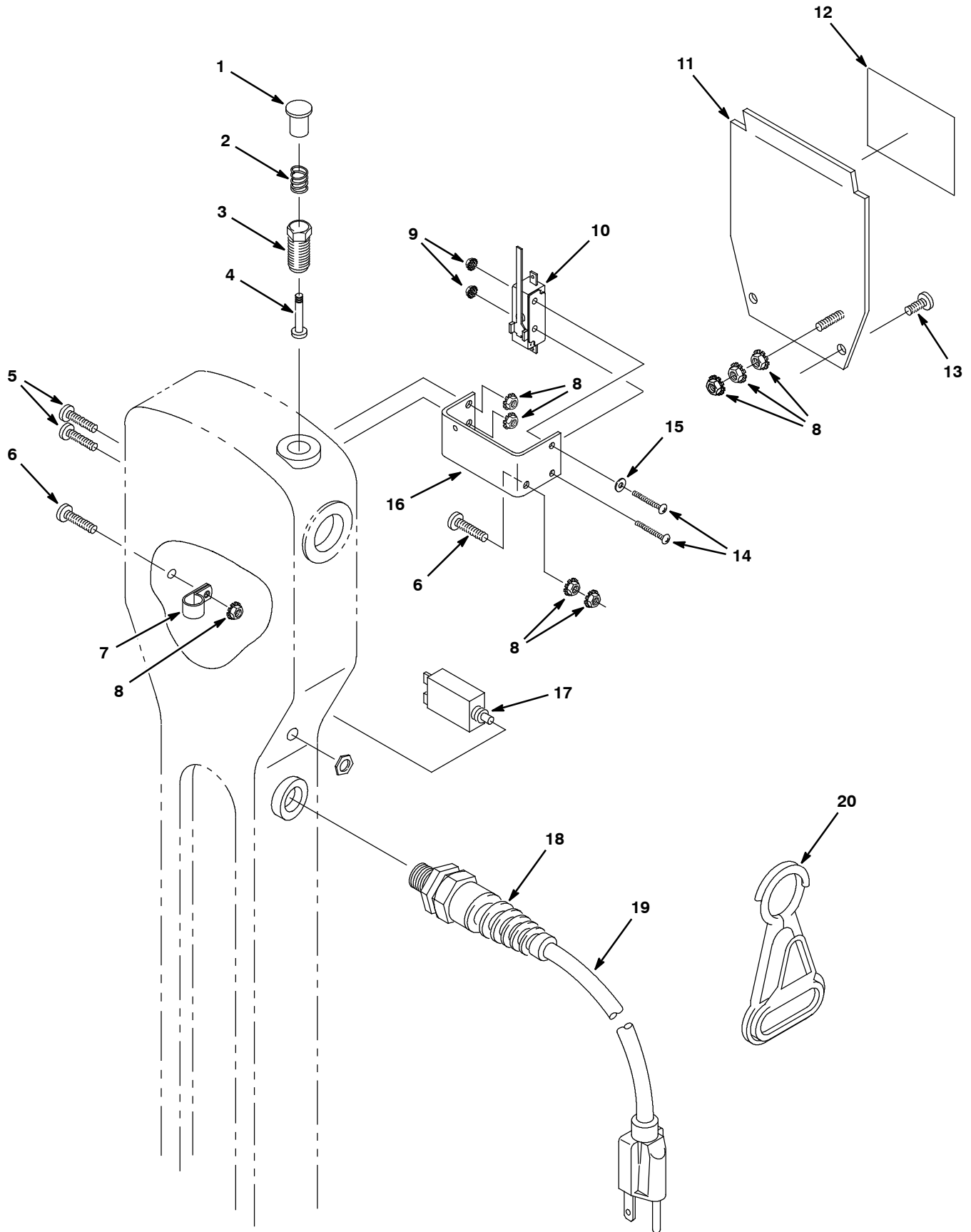

HANDLE GROUP - CONTD

Ref.	Part No.	Serial Number	Description	Qty.	
1	230855	(00000000-) Knob, Button, Lock Release, Alm	1	
2	140401	(00000000-) Spring, Cmpr, Lock Button	1	
3	230857	(00000000-) Lock, Soc	1	
4	230856	(00000000-) Pin, Lock, Release	1	
5	140823	(00000000-) Screw, Trs, Phl, 10- 24 X 0.62, Ss	2	
6	140900	(00000000-) Screw, Trs, Phl, 10- 24 X 0.75, Ss	2	
7	140328	(00000000-) Clamp, Cable, Nyl, 0.38d, Blk	1	
8	140519	(00000000-) Nut, Hex, Lock, #10- 24, Kep, Ss	8	
9	140539	(00000000-) Nut, Hex, Lock, #06- 32, Kep, Ss	2	
10	1013132	(00000000-) Switch, Lever, Snap Actn (120V)	1	
10	1013132	(00000000-) Switch, Lever, Snap Actn (230V)	2	
▽	11	9001922	(00000000-) Plate, Handle, Rear W/ Label	1
▲	12	1026385	(00000000-) Label, Warning 4x4 Na [Ac Floormachines]	1
▽	11	9007738	(00000000-) Plate, Handle, Rear, Afmkt [Fm- 43- Ss]	1
▲	12	1048797	(00000000-) Label, Warning 4x4 [Ac Flrmach En,Es,Ch] (China)	1
13	140197	(00000000-) Screw, Trs, Phl, 10- 24 X 0.38, Sems, Ss	2	
14	140829	(00000000-) Screw, Pan, Phl, 06- 32 X 1.00, Ss (120V)	2	
14	140830	(00000000-) Screw, Pan, Phl, 06- 32 X 1.62, Pl (230V)	2	
15	140032	(00000000-) Washer, Flat, 06, Ss	1	
16	230854	(00000000-) Bracket, Switch	1	
17	605201	(00000000-) Circuitbreaker, 17.0a (120V)	1	
17	130752	(00000000-) Circuitbreaker, 20.0a (230V)	1	
18	602849	(00000000-) Strainrelief, Cord, Ele, Pm08, Blk Nyl (120V)	1	
18	130167	(00000000-) Strainrelief, Cord, Ele, Pm08, Blk Nyl (230V)	1	
19	610974	(00000000-) Cord, Power, 14/3, 75ft Yel W/ Grip[Sto] (120V)	1	
19	600396	(00000000-) Cord, Power, 1.5mm2/3 Blk [23meter Euro] (230V)	1	
20	130176	(00000000-) Clip, Cord, Strainrelief [Belt]	1	

▽ ASSEMBLY

▲ INCLUDED IN ASSEMBLY

BASE GROUP

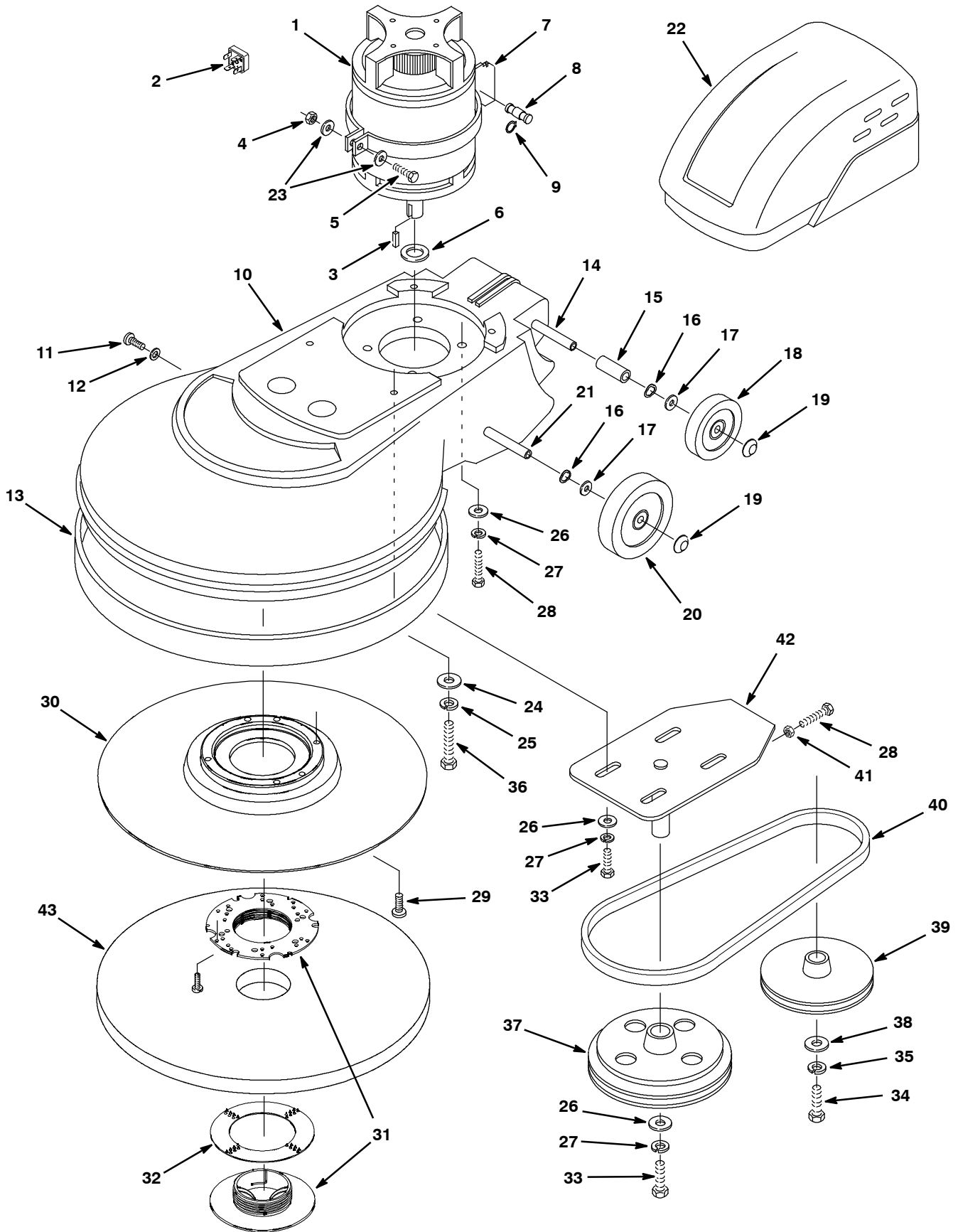

BASE GROUP

Ref.	Part No.	Serial Number	Description	Qty.
▽	1	1058286	(00000000-) Motor, 115v, 1.5 Hp, 3200 Rpm (120V)	1
▲		22117	(00000000-) Brush, Carbon [1pick=1pc]	4
▲	2	190753	(00000000-) Rectifier, 60a/600v	1
▽	1	609444	(00000000-) Motor, Ele, 230vac 3200rpm 50hz (230V)	1
▲		190311	(00000000-) Brush, Carbon [1pick=1pc]	4
▲	2	190312	(00000000-) Rectifier	1
	3	140628	(00000000-) Key, Sq, 0.19 X 0.19, 1.00l	1
	4	140546	(00000000-) Nut, Hex, Lock, .31- 18, NI, Ss	1
	5	140221	(00000000-) Screw, Hex, .31- 18 X 1.25, Ss	1
	6	230447	(00000000-) Spacer, P/M, 0.76b 1.00d 0.35l, Stl	1
	7	230918	(00000000-) Latch, Plt Handle	1
	8	230772	(00000000-) Pin, Spring	1
	9	140421	(00000000-) Ring, Retaining, .50id	2
	10	9007685	(00000000-) Base, 20.0, Hi Spd, Rm- Blk, Afmkt	1
	11	140824	(00000000-) Screw, Trs, .25- 20 X 0.62, Phl, Ss	2
	12	140003	(00000000-) Washer, Flat, 0.25b 1.00d , Ss, Fendr	2
	13	602544	(00000000-) Bumper, Head, .47 X 1.8 X 47.8, Pvc	1
	14	608910	(00000000-) Axle, .5d X 12.92l [See Notes]	1
	15	140148	(00000000-) Sleeve, P/M, 0.50b 0.63d 1.4l, PI	2
	16	4252	(00000000-) Washer, Flat, .50 Compression, Zn	4
	17	3148.816	(00000000-) Washer, Flat, 0.52b 0.88d .06, Stl, PI	4
	18	103066	(00000000-) Wheel, 04.0d 1.50w 0.50b, Gray	2
	19	103019	(00000000-) Nut, Retainer, 0.50d 0.29l, Ss	4
	20	103067	(00000000-) Wheel, 05.0d 1.50w 0.50b, Gray	2
	21	608913	(00000000-) Axle, .5d X 15.73l [See Notes]	1
	22	1033088	(00000000-) Cover, Motor, Rm- Cphg, Trimmed	1
	23	140027	(00000000-) Washer, Flat, 0.35b 0.75d .04, Ss	2
	24	140000	(00000000-) Washer, Flat, 0.28b 0.62d .04, Ss	4
	25	140016	(00000000-) Washer, Lock, Split, 0.25, Ss	4
	26	32492	(00000000-) Washer, Flat, 0.38, Std	9
	27	140017	(00000000-) Washer, Lock, Split, 0.38, Ss	9
	28	611048	(00000000-) Screw, Hex, .38- 16 X 1.25, Ss	5
	29	140949	(00000000-) Screw, Btn, .31- 18 X 1.25, PI	4
▽	30	1033499	(00000000-) Driver, Pad, 20.0d, Flex	1
▲	31	603538	(00000000-) Lock, Cntr, Gray	1
▲	32	32505	(00000000-) Washer, Flat, 92b 156d 2.6l, Pad Driver	1
	33	02994	(00000000-) Screw, Hex, .38- 16 X 0.75, Ss	5
	34	02991	(00000000-) Screw, Hex, .31- 18 X 0.75, Ss	1
	35	140015	(00000000-) Washer, Lock, Split, 0.31, Ss	1
	36	579212	(00000000-) Screw, Hex, .25- 20 X 2.00, Ss	4
	37	611695	(00000000-) Pulley, Pad Driver, Mold, 2 Brg	1
	38	25732	(00000000-) Washer, Flat, 0.36b 1.25d .09, PI	1
	39	240075	(00000000-) Pulley, Drive, 3.25d, Belt,V[1200rpm Hs]	1
	39	240076	(00000000-) Pulley, Drive, 4.00d, Belt,V[1600rpm Hs]	1
	40	240078	(00000000-) Belt (1200rpm)	1
	40	240079	(00000000-) Belt, Drive (1600rpm)	1
	41	140545	(00000000-) Nut, Hex, Jam, .38- 16, Fin, Ss	1
	42	230448	(00000000-) Bracket, Casting, Drive	1
	43	611788	(00000000-) Pad, 20.0[Burnish, Hairblend,1pick=1ctn] (Qty 5 Pads)	1

▽ ASSEMBLY

▲ INCLUDED IN ASSEMBLY

ELECTRICAL DIAGRAM, 120V

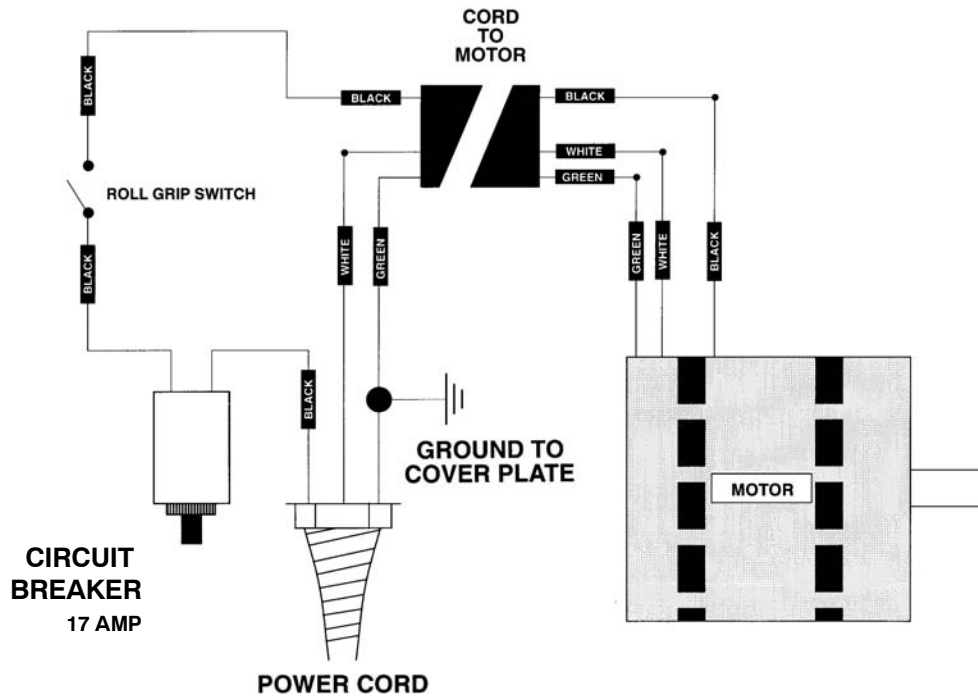

ELECTRICAL DIAGRAM, 230V

